OWNER'S MANUAL



P.O. Box 1520
Sykesville, MD 21784-1520
(410) 549-6083
Fax: (410) 549-6082

**Manufacturing High Quality, High Efficiency
Heat Pump Pool Heaters**

TABLE OF CONTENTS

SAFETY CONSIDERATIONS	2
INSPECTION	2
GENERAL INFORMATION	2
INSTALLATION	2
WATER FLOW & CONNECTIONS	2-3
ELECTRICAL CONNECTIONS	4
MODES OF OPERATION	5
WIRING DIAGRAMS	6
ELECTRONIC CONTROL PANEL	7
CHEMICAL USE	8
START-UP	9-10
MAINTENANCE	10
TROUBLESHOOTING CHECKLIST	11
CALLING FOR SERVICE	12
WARRANTY	13
WARRANTY REGISTRATION	14

ALL IN-GROUND MODELS

INSTALLATION, OPERATION, MAINTENANCE & SERVICE



97PACT-02

SAFETY CONSIDERATIONS

- Qualified personnel should perform installation, maintenance and service.
- Make sure all field wiring conforms to the heater specifications and all national and local codes.
- Disconnect all power sources before performing any maintenance or service to the heater.

INSPECTION

Immediately upon receipt, inspect cartons and their contents for damage due to transit. Damage, if found, should be noted on delivery papers and a claim filed with the carrier. Also, check unit data plate to make sure you have the proper model, before installing.

GENERAL INFORMATION

The information in this manual was prepared to assist in the proper installation, operation, maintenance and service of your new heat pump pool heater. Please read the entire manual and follow all instructions. Improper installation and use can result in damage to the heater, unsatisfactory operation, and may void the warranty. Retain this manual for quick reference.

INSTALLATION

When selecting a location consider the following:

- Heater must be located outdoors.
- Minimum of 24” of clearance on access / service side of heater.
- Minimum of 18” of clearance on all three air intake sides of heater.
- Minimum of 48” of clearance for air discharge (top of unit).
- The heater should sit on a solid level surface sufficient above grade to prevent water from entering it, and allowing condensate to drain from base.
- The length of water piping and electric should be kept to a minimum to avoid capacity loss and decreased efficiency.

WATER FLOW & CONNECTIONS

Water connections are made at the rear of the heater. Both water in and out are labeled just above the water connections. LEFT REAR = WATER OUT and RIGHT REAR = WATER IN. 2” unions are supplied and are made to accept 2” rigid PVC pipe. NOTE: unions can be used for quick drainage of your heater and winterizing.

- Heater must be piped downstream from filter in the pool return line.
- **Inline chlorinators must be piped downstream from heater. A check valve must be installed between the heater and chlorinator to prevent drain back of the chlorine when the pump is off. A chemical trap may also be piped at least six (6) inches above the**

height of the chlorinator.

- When all the plumbing connections are complete, and ample drying time is allowed, run the filter pump and check the entire system for water leaks.
- Make sure filter is clean and there are no obstructions in the filtering system.
- Proper water flow is essential to the performance of your heater. The minimum flow rate is 20 GPM.

TYPICAL WATER FLOW CONNECTIONS

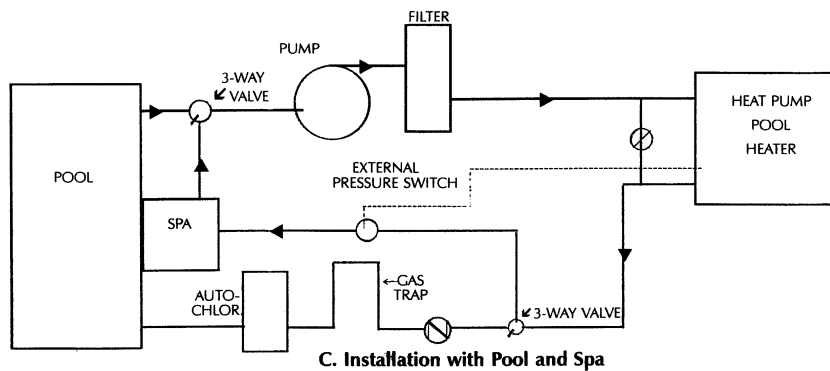
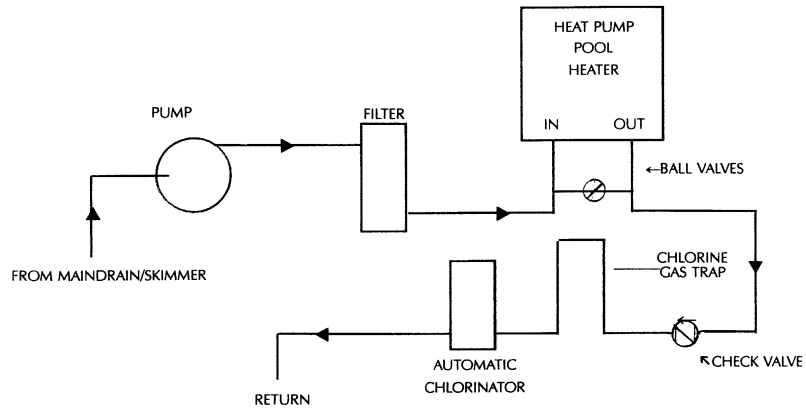
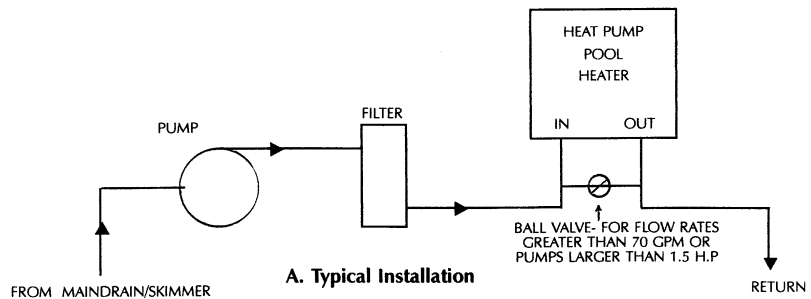

ELECTRICAL CONNECTIONS

Field connections must comply with national and local codes. The work must be done by a qualified electrician.

Heater must be permanently grounded and bonded.

Bonding will drastically reduce the chances of electrolysis, “Electrical Corrosion.”

Use copper conductors only.

Disconnect all power sources before performing any work on unit.

Standard Power Supply: 230/60/1

See unit data plate for specific ampacity.

Wiring Main Power Supply

1. Remove the screws from the plastic front panel, located on the control display side of the unit.
2. Remove the screws from the front panel of the control box.
3. Route weather tight flexible conduit through the opening at the base of the unit. Connect conduit to the bottom of the electrical control enclosure. A knockout is provided in the bottom of the electrical control enclosure to accept either a $\frac{3}{4}$ ” or 1” fitting. Mounting conduit directly to the electrical control enclosure will ensure a moisture tight seal, extending the life of the heater.
4. Attach grounding conductor to the ground lug provided inside the electrical control enclosure.
5. Install L1 and L2 input conductors to the input lugs of the compressor contactor.
6. Connect bond wire (at least #8 solid copper wire) from bond lug on the right side of coil header plate to the pool pump bonding terminal or other suitable location.

MODES OF OPERATION

To Change Between Pool and Spa Setpoints Manually:

This is the default factory setting (jumper on pins 1-2) and allows the user to change between the pool and spa setpoints by using the mode button located on the front control panel. The use of an external water pressure switch **IS NOT** required for this mode of operation.

To Change Between Pool and Spa Setpoints Automatically:

This change can be done automatically as the water flow is directed to either the pool or spa. The use of an external water pressure switch in the spa piping **IS** necessary. A two-wire control circuit must be connected from the water pressure switch to the terminals 9 and 10 on the terminal strip located in the electrical control enclosure. The mode jumper must be on pins 2-3 for this mode of operation. See figure 1 below for pin settings.

Remote Thermostats and Controllers:

If a remote thermostat or another control system is to be used to operate the heater, a normally open dry contact can be made at terminals 11 and 12 on the terminal strip located in the electrical control enclosure. Remove the red jumper from terminals 11 and 12 on the terminal strip and install the remote control system. The mode jumper must be on pins 3-4 for this mode of operation. See figure 1 below for pin settings.

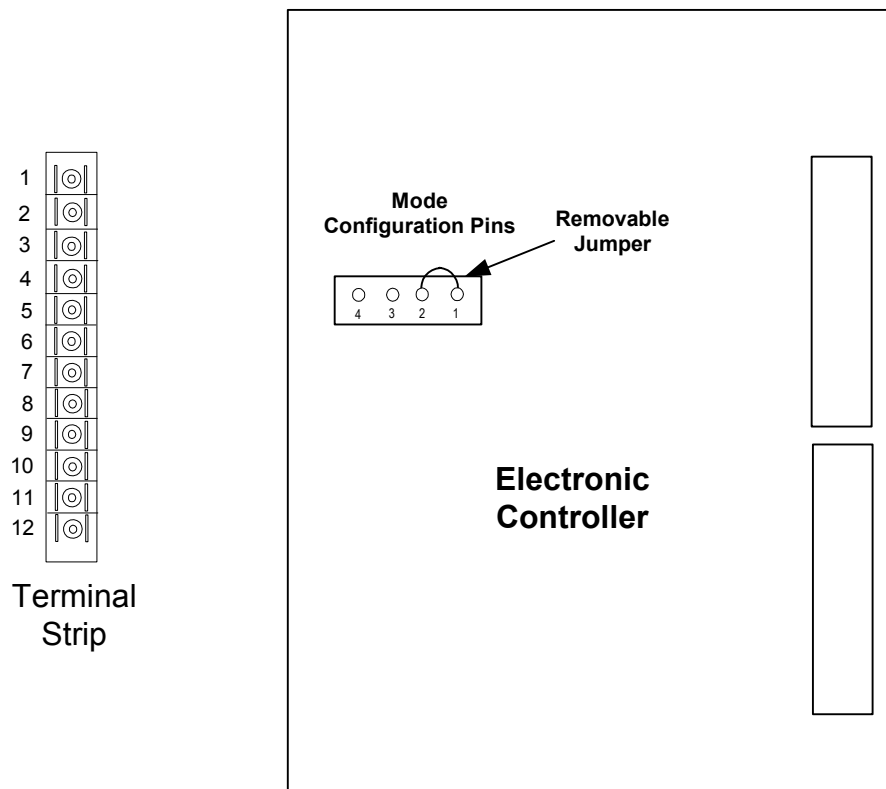
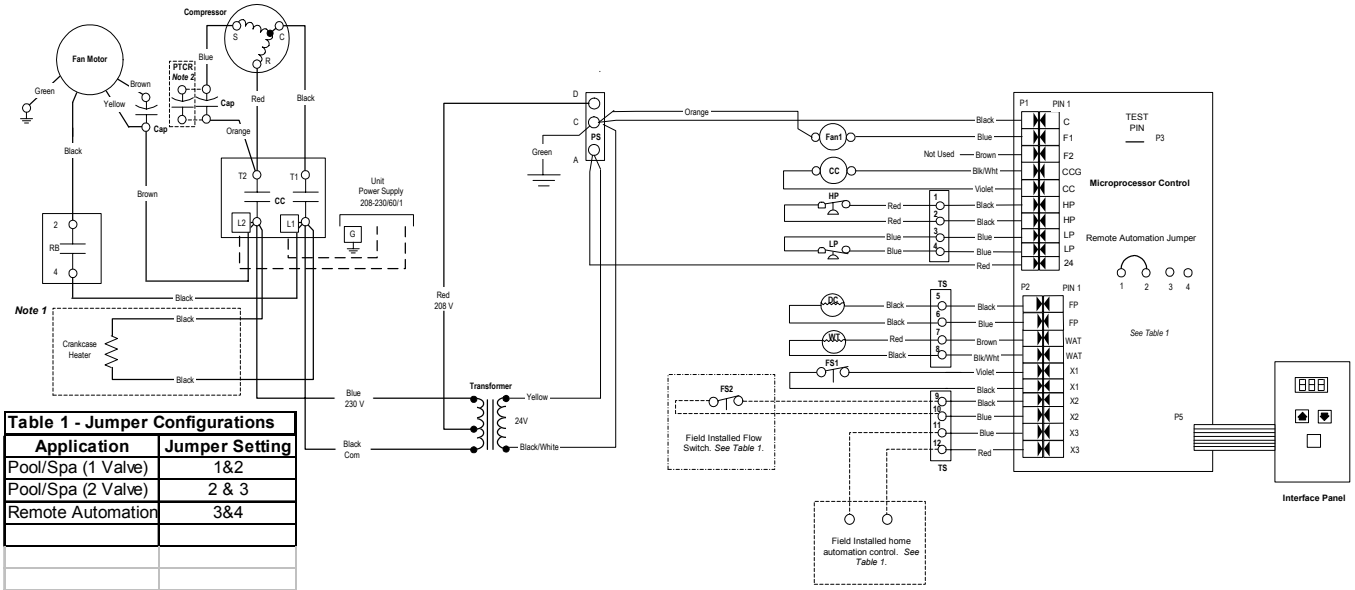

Figure 1 – Terminal Strip & Mode Configuration Pins

WIRING DIAGRAMS

Pool Heater Series - Wiring Schematic 230/60/1

97P675-01 7/25/03



Application	Jumper Setting
Pool/Spa (1 Valve)	1&2
Pool/Spa (2 Valve)	2 & 3
Remote Automation	3&4

Legend				
<ul style="list-style-type: none"> Factory low voltage wiring Factory line voltage wiring Field low voltage wiring Field line voltage wiring Optional block Quick connect terminal Screw terminal - field connection Wire nut 	<ul style="list-style-type: none"> CC - Compressor contactor DC - Defrost Cycle WT - Water Temperature HP - High pressure switch LP - Low pressure switch Fan - Fan relay FS1 - Flow Switch 1 FS2 - Flow Switch 2 RM - Remote Automation 	<ul style="list-style-type: none"> L1 - Field wire lug Ground Relay Contacts - N.O., N.C. Polarized connector 	<ul style="list-style-type: none"> Switch - High pressure Switch - Low pressure Relay coil Capacitor Thermistor 	<p>Notes:</p> <ul style="list-style-type: none"> 1 - Only on 105 models. 2 - Only on 080 models.

Notes:

1. Use only copper conductors.
2. Connect field wiring in grounded rain-tight conduit, per rating plate.
3. Connect bond wire to pool steel using #8 solid copper wire or larger.
4. All wiring must conform to national (N.E.C.) and local electrical codes.

ELECTRONIC CONTROL PANEL

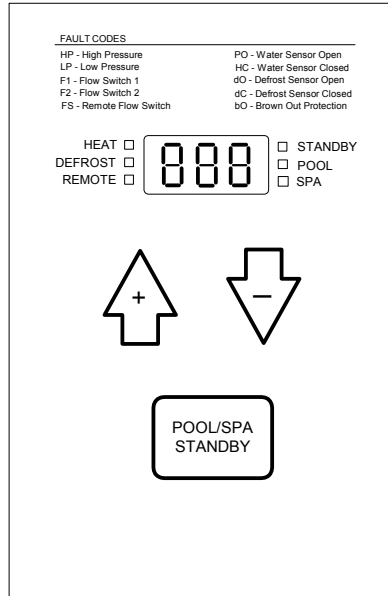

Figure 2 – User Interface Control Panel

Control Settings

Temperature Setpoint

- Temperature setpoint maximum for POOL mode is 95°F (35°C).
- Temperature setpoint maximum for SPA mode is 104°F (40°C).

To change the temperature setpoint, press the POOL/SPA/STANDBY button until you reach either POOL or SPA mode, this will prompt the control to display the current temperature setpoint. Hold either UP or DOWN button to scroll to your desired temperature setpoint. Once your new temperature setpoint has been reached, release the UP or DOWN button. Your new setpoint will be displayed for fifteen seconds then revert back to the actual pool or spa water temperature.

Note: When the mode jumper is in position 3-4 the setpoint must be changed on the remote control system.

Selecting Pool or Spa Mode

Press the POOL/SPA/STANDBY button until you reach the desired mode. The LED indicator light will verify the mode that has been selected. Note: When the mode jumper is in position 2-3 or 3-4 the mode is determined by the external water pressure (flow) switch or remote controller.

CHEMICAL USE

Water quality must be checked regularly and maintained within recommended limits at all times. Failure to maintain the proper water quality will greatly reduce the life of your heater.

- Never add chemicals directly into skimmer.
- Automatic chlorinators must be piped downstream from the heater. A check valve must be installed between the chlorinator and heater to prevent raw chlorine from draining back into the heater. A chemical trap may be piped at least six (6) inches above the chlorinator. See piping diagram B.

Always maintain the following water quality requirements:

PH LEVEL 7.4 to 7.8
CHLORINE CONCENTRATION 1 to 5 PPM
TOTAL ALKALINITY 100 to 200 PPM
CALCIUM HARDNESS 100 to 300 PPM

START-UP

Before proceeding with this section make certain all plumbing connections are airtight and leak free.

Flow rates should not exceed 70 GPM maximum. Use of an external bypass is necessary at 70 GPM and above. Minimum flow rate is 20 GPM.

- Turn filter pump time clock to the ON position and set filter pump hours. For initial heating, the pool heater and filter pump may need to run continuously until your desired temperature is reached. After initial heating is achieved, the heater will run only to maintain your desired temperature.
- Turn power supply to heater ON.
- The amber Standby LED will be activated.
- Select POOL or SPA and set your desired water temperature by scrolling either up or down.
- If your programmed water temperature is above the actual water temperature, the red HEAT LED will light up indicating HEAT mode. The fan will start, and then the compressor will start.

NOTE: Each time the compressor turns off, it is protected by a 3-5 minute anti-short cycling delay.

Initial Heating

Initial heating may require you to run your heater and filter pump continuously for at least 24 hours, or more, depending on the following factors:

- Temperature difference between actual water temperature and desired water temperature.
- Size of pool.
- Ambient air temperature, the cooler the air temperature the longer the heating time.
- Heat loss (evaporative, convective, radiative and conductive).
- A pool cover / solar blanket may reduce initial heating time by up to 50 percent.

Defrost Cycle

The heat pump pool heater has automatic defrost. When the outdoor temperature drops below 40 °F, frost may start to form on the evaporator coil. Frost buildup will be heaviest on humid days when the temperature is between 35-40°. During the defrost cycle, the Defrost LED will be illuminated to indicate that the unit is defrosting. During this time the fan is running and the compressor is inactive.

Internal Protection Analyzers

The heater is equipped with internal devices to monitor and protect the integrity of the unit. Should an abnormal condition occur, these devices will interrupt the operation of the unit and may display the appropriate code on the control panel.

Reducing Heat Loss - Pool Cover / Solar Blanket

We highly recommend the use of a pool cover / solar blanket. Covering your pool is the single most cost effective means of reducing heat costs from 50 to 70 percent. Heating a pool without a cover is like heating a house without a roof. They also reduce the amount of maintenance costs. By reducing evaporation, covers reduce the quantity of chemicals needed.

Because evaporation accounts for about 70 percent of pool heat loss, the beneficial effect of using a pool cover / solar blanket can be dramatic.

Wind Speed Reduction

Reducing wind velocity at the water surface reduces convective and evaporative losses. Fences, trees, hills, or tall hedges close to the pool perimeter are effective windbreaks. Locate these obstructions to take maximum advantage of their effectiveness as windbreaks, without shading the pool surface from the sun.

MAINTENANCE

WARNING: DISCONNECT ELECTRICAL POWER TO UNIT BEFORE STARTING ANY MAINTENANCE TO PREVENT SERIOUS INJURY FROM SHOCK.

Protecting your Heater

- Keep your pool filter system clean and free of restrictions to ensure proper water flow.
- Check water chemistry regularly. Misuse of chemicals will cause permanent damage to your heater and other pool equipment. Manufacturers can void warranties for damage as a result of poor water quality.
- Free airflow is essential. Keep the evaporator coil clean and free of weeds, leaves, glass clippings, dirt and other debris that will decrease the airflow. Keep fences and shrubs away from air inlets (sides and back of heater).
- Frequent rinsing of the evaporator with fresh water will remove build up from its surface. Always spray the coil gently with a regular garden hose being careful not to bend aluminum fins.
- Regular cleaning of the cabinet will improve its appearance and extend the life of the finish.

Winterizing

When the heater is exposed to freezing temperatures, it is essential that all water within the unit be properly drained. When water freezes it expands, damaging piping.

- Turn thermostat settings to OFF. Turn filter pump to OFF.
- Turn power to unit OFF (i.e. pull disconnect or turn circuit breaker OFF).
- Disconnect water inlet and outlet unions at the back of the unit, be careful not to lose rubber o-rings.
- Flush the heater piping out with fresh water to remove any residual chemicals.
- Use low-pressure air or vacuum to remove water that has accumulated inside the piping of the heater.

TROUBLESHOOTING CHECKLIST

1. Check to be sure that the electrical power is on. Reset the breakers or replace fuses if necessary.
2. Check to be sure the electronic control panel is set properly. The unit must be in either the Pool or Spa mode and the desired temperature must be set above the actual pool or spa temperature for the heater to run. If an error code is displayed, reference the table below to determine the cause.
3. Check to make sure the evaporator coil has enough clearance and that there are no restrictions to its airflow.
4. Certain ambient air conditions may cause the heater to go into defrost mode. The Defrost mode will be indicated by the Defrost LED.

NOTE: IT IS NORMAL FOR WATER TO DRIP FROM THE DRAINHOLES AT THE BASE OF THE HEATER. THE UNIT PRODUCES CONDENSATE WHEN IT OPERATES.

The following table lists error codes as they would appear on the electronic control display. In the event that an error does occur, check the possible causes list for the corresponding error to correct the problem.

Error Code	Description	Possible Causes
F1	Internal Flow Switch Open	Little or no water flow The pump is not running The filter is dirty or clogged Shortage of water to pump, air leak Undersized pump Valves not in correct position Filter in backwash mode Water pressure switch needs adjustment or is defective
FS	Internal Flow Switch Open Remote Mode	Same as above
HP	High Pressure Switch Open	Low water flow to heater Defective high-pressure switch
LP	Low Pressure Switch Open	Evaporator coil is dirty Fan motor not running Low refrigerant pressure Defective low pressure switch
PO	Water Thermistor Open	Loose sensor wire Defective water thermistor
HC	Water Thermistor Closed	Wire terminals touching Defective water thermistor
dO	Defrost Sensor Open	Loose sensor wire Defective defrost sensor
Dc	Defrost Sensor Closed	Wire terminals touching Defective defrost sensor
bO	Control Voltage Below 18VAC	Low supply voltage to the unit

CALLING FOR SERVICE

- Please eliminate any water flow problems before calling for service.
- If you are unable to contact the installing agent, please contact *AQUA COMFORT TECHNOLOGIES, LLC*. A factory representative will assist you or your serviceman over the phone.

SERVICE PERFORMED WITHIN THE WARRANTY PERIOD MUST BE APPROVED BY AQUA COMFORT TECHNOLOGIES, LLC PRIOR TO SERVICE BEING PERFORMED AND ONLY BY AN AQUA COMFORT TECHNOLOGIES, LLC AUTHORIZED TECHNICIAN. SEE WARRANTY FOR DETAILS.

Please have the following ready before calling:

IN-GROUND MODEL #:

SERIAL #:

DATE OF INSTALLATION:

NAME OF OWNER:

ADDRESS:

CONTACT #:

NATURE OF PROBLEM:

LIMITED WARRANTY HEAT PUMP POOL HEATERS

AQUA COMFORT TECHNOLOGIES, LLC (ACT) warrants only to the original owner, the HEAT PUMP POOL HEATER to be free of defects in materials and workmanship for a limited ten (10) year term as follows: One (1) year full parts and labor, years two (2) through ten (10) the compressor and heat exchanger (part only). This warranty does not include transportation charges for equipment or component parts to or from the factory. This warranty is valid only in the Continental U.S. The labor for repair or replacement of defective parts will be provided by ACT subject to the conditions of this limited warranty.

THE EFFECTIVE DATE OF WARRANTY is the date of installation, if properly documented, otherwise the date of manufacture plus three (3) months.

THIS WARRANTY WILL NOT APPLY TO: A) Malfunction or damage resulting from installation, operation, maintenance, voltage conditions, or service not in accordance with ACT specifications. B) Malfunction or damage due to the failure to perform normal maintenance as outlined in the Owner's Manual. C) Malfunction or damage due to conditions not intended for original use of the unit. D) Malfunction or damage due to negligence, abuse, freezing conditions, accident, or acts of God. E) Malfunction or damage from plants or animals. F) Malfunction or damage from the attachment of accessories not authorized by ACT. G) Unnecessary service calls due to erroneous operational reports, maintenance and electrical service. H) Units sold outside the continental United States.

SERVICE PERFORMED WITHIN THE WARRANTY PERIOD must be approved by ACT **PRIOR** to service being performed, and must be performed by an authorized technician. The warranty is void if the unit is repaired by anyone unauthorized by ACT. Reimbursement for replacement parts or repair services that are not authorized or performed by ACT are not covered under this limited warranty.

WARRANTY PARTS will be replaced or repaired at the discretion of ACT. Shipping of warranty parts is not included. Defective parts must be returned to ACT within the warranty period for validation. ACT is not liable for the labor involved in the unauthorized repair, or replacement costs including parts and labor. This warranty is in lieu of all other warranties, expressed or implied, written or oral. The liability of ACT shall not exceed the cost of the repair or replacement of defective parts; ACT is not liable for damages of any sort whatsoever, including incidental and consequential. There are no implied warranties of fitness for a particular purpose that apply to this product.

Owner _____
Address _____
City/St/Zip _____
Installation Date _____
Contractor _____
Address _____
City/St/Zip _____
In-Ground Model # _____
Serial # _____

**KEEP FOR YOUR RECORDS
DO NOT MAIL CERTIFICATE**

AQUA COMFORT TECHNOLOGIES, LLC
P.O. BOX 1520
SYKESVILLE, MD 21784-1520
(410) 549-6083 / Fax: (410) 549-6082

WARRANTY REGISTRATION

The Warranty Registration Form must be filled out in full and mailed to AQUA COMFORT TECHNOLOGIES, LLC within sixty days from the date of installation. Do not mail Warranty Certificate.

MAIL TO:

**AQUA COMFORT TECHNOLOGIES, LLC
ATTN: WARRANTY DEPT. (WA)
P.O. BOX 1520
SYKESVILLE, MD 21784-1520**

WARRANTY REGISTRATION HEAT PUMP POOL HEATER

Name of Owner _____ Phone _____

Address _____

City, State _____ Zip + 4 _____

Installation Date _____ Dealer _____

In-Ground Model # _____

Serial # _____

Pool Surface Area _____ ft x _____ ft

Is Pool Covered? Yes No (Circle One)

Is Pool Screened In? Yes No (Circle One)

Is an In-Line Chlorinator Used? Yes No (Circle One)

Questions / Comments

Signature _____ Date _____